

# teknè



① Il nuovo paesaggio domestico trae dagli spazi nuove risorse formali, configura una nuova estetica del calore. TEKNÉ, il termosifone visibile, oggetto formale che cattura lo sguardo. Sia lucido che satinato TEKNÉ ha altezze variabili per la migliore adattabilità agli ambienti e per la massima libertà degli spazi.

② The new domestic landscape draws new form resources from spaces, configuring a new heat aesthetic. TEKNÉ, the visible radiator, an object that draws gazes. Both in its satined and polished finishes TEKNÉ is available in various heights, allowing for the utmost adaptability to environments and the utmost freedom as regards spaces.

③ Le nouveau paysage domestique rassemble les ressources de ces nouveaux espaces formels, la configuration d'un nouveau visage de la chaleur. Le TEKNÉ est un objet que l'on montre.

④ Die neue häusliche Landschaft zieht neue Formen aus Räumen und schafft so eine neue Ästhetik von Wärme. TEKNÉ, eine sichtbare Heizung, zieht Blicke auf sich. Sowohl in seiner satinierten als auch glänzenden Ausführung ist TEKNÉ in verschiedenen Höhen verfügbar und erlaubt so die bestmögliche Anpassung an die Umgebung und größtmögliche Freiheit bei der Gestaltung des Raumes.

⑤ El nuevo paisaje doméstico atrae nuevos recursos desde los espacios formales, configurando una nueva estética del calor. TEKNÉ tanto en brillo como en satinado con diferentes alturas rea una mejor adaptabilidad al ambiente y la máxima libertad de espacios.

⑥ Новый домашний пейзаж рисует новые ресурсы пространств, создавая новую эстетику тепла. TEKNÉ - это видимый радиатор, притягивающий взгляды. Как глянцевый, так и сатиновый TEKNÉ может иметь различную высоту для лучшей адаптации к окружающей среде, а также для максимальной свободы выбора пространства.



# teknè

Design Simone Micheli





raffurale.com

②

# INFORMAZIONI TECNICHE TECHNICAL INFORMATION INFORMATIONS TECHNIQUES TECHNISCHE INFORMATION INFORMACIÓN TÉCNICA



- (I) Alluminio
- (GB) Aluminum
- (F) Aluminium
- (D) Aluminium
- (E) Aluminio



- (I) Acciaio
- (GB) Steel
- (F) Acier
- (D) Stahl
- (E) Acero



- (I) Acciaio inossidabile
- (GB) Stainless steel
- (F) Acier inoxydable
- (D) Rostfreier Stahl
- (E) Acero inoxidable



- (I) Alimentazione ad acqua
- (GB) Water Feeding
- (F) Fontionnement hydraulique
- (D) Warmwasser-betrieb
- (E) Sistema hidràulico



- (I) Alimentazione elettrica
- (GB) Electric Feeding
- (F) Fontionnement électrique
- (D) Elektro-betrieb
- (E) Sistema eléctrico



- (I) Alimentazione combinata
- (GB) Combined Feeding
- (F) Fontionnement mixte
- (D) Kombi-betrieb
- (E) Sistema mixto



- (I) Su misura
- (GB) Tailor-made
- (F) Construit sur mesure
- (D) Sonder-maß
- (E) Hecho a medida

# FINITURE FINISH FINITION ENDBEARBEITUNG ACABADO SUPERFICIAL



RAL

- (I) Tutti i colori RAL lucidi
- (GB) All RAL Polish colors
- (F) Totes les couleurs RAL brillant
- (D) Alle glänzende RAL Farben
- (E) Todos los colores RAL brillantes



MAT

- (I) Anodizzato Matt
- (GB) Anotized matt
- (F) Anodisé mat
- (D) Mattes anotiziert
- (E) Anotizado matty



WHITE  
TEXT

- (I) Bianco testurizzato
- (GB) Textured white
- (F) Blanc texturé
- (D) Texturiert weiß
- (E) Texturizado blanco



WHITE

- (I) Bianco 9016
- (GB) White Ral 9016
- (F) Blanc RAL 9016
- (D) Weiß RAL 9016
- (E) Blanco RAL 9016



LUX

- (I) Anodizzato lucido
- (GB) Anotized Polished
- (F) Anodisé poli
- (D) Glänzend Politiert
- (E) Anotizado brillante



INOX  
LUX

- (I) Acciaio inox lucido
- (GB) Polished Stainless steel
- (F) Acier inoxydable poli
- (D) Glänzend rostfreie Stahl
- (E) Acero inoxidable pulido



SAT

- (I) Anodizzato satinato
- (GB) Anotized Satin
- (F) Anodisé satiné
- (D) Mattes satiniert
- (E) Anotizado satinado



ANTH

- (I) Antracite
- (GB) Anthracite
- (F) Anthracite
- (D) Anthrazit
- (E) Antracita



INOX  
BRUSHED

- (I) Acciaio inox spazzolato
- (GB) Satined Stainless steel
- (F) Acier inoxydable satiné
- (D) Satiniert rostfreie Stahl
- (E) Acero inoxidable satinado



GOLD

- (I) Acciaio cromato dorato
- (GB) Golden-chromed plated steel
- (F) Acier chromé doré
- (D) Goldgelb Chromstahl
- (E) Acero dorado cromado



CHROME

- (I) Acciaio cromato
- (GB) Chromed-plated Steel
- (F) Acier chromé
- (D) Chromstahl
- (E) Acero cromado



# teknè



- Ⓛ Modelli 600 -1700-1900 in versione sospesa.
- ⓐ 600-1700-1900 models in wall-mounted version.
- ⓕ Modèles 600 -1700-1900: pour installation suspendue.
- ⓔ Modelos 600 -1700-1900: colgado a la pared.
- ⓓ Modelle 600 -1700-1900 in wandhängender Version.

	H (mm)	D (mm)	L (mm)	 (lt)	 (W)		i (mm)	Finiture / Finishings / Finitions / Acabado / Oberflächen
					Δt 50°	Δt 30°		
H 700-12 F	683	80/105	575	2,4	516	284	540	RAL              LUX              SAT              MAT              WHITE TEXT              WHITE              ANTH
H 700-17 F	683	80/105	825	3,4	731	402	540	
H 700-25* F	683	80/105	1225	5,0	1075	591	540	
H 700-31* F	683	80/105	1525	6,2	1333	733	540	
H 1800-6 F	1783	80/105	275	3,1	728	400	1640	
H 1800-10 F	1783	80/105	475	5,2	1213	667	1640	
H 2000-12 F	1983	80/105	575	6,9	1624	893	1840	
H 600-12	566	80/105	575	2,4	516	284	540	
H 600-17	566	80/105	825	3,4	731	402	540	
H 600-25	566	80/105	1225	5,0	1075	591	540	
H 600-31	566	80/105	1525	6,2	1333	733	540	
H 1700-6	1666	80/105	275	3,2	728	400	1640	
H 1700-10	1666	80/105	475	5,2	1213	667	1640	
H 1900-12	1866	80/105	575	6,9	1624	893	1840	

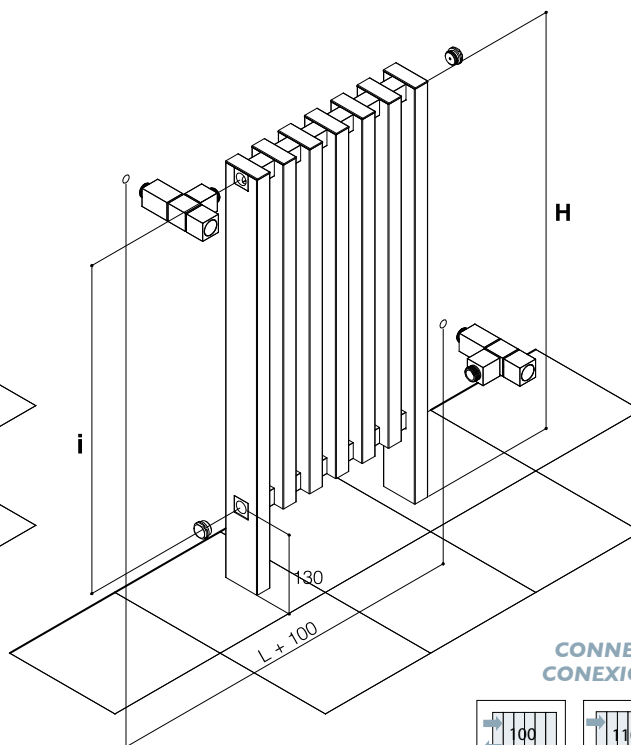
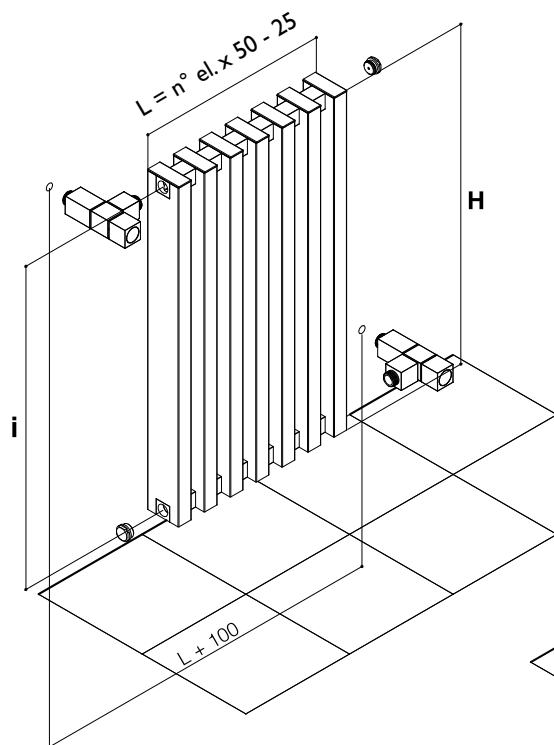
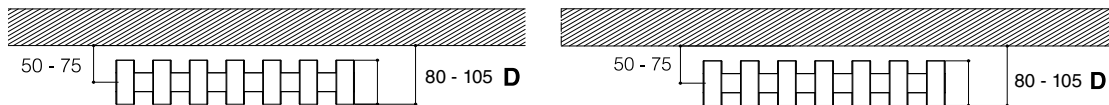

## KIT VALVOLE VALVES KIT (pag. 144)

manual	termostatic
1	1T + 14
2	2T + 14
3	3T + 14
4	4
5	5T
6	6
7	
8	
9	
10	
11	
12	
13	13

● Valvole disponibili/  
Suitable valves

## CONNESSIONI CONNECTIONS / CONNEXIONS CONEXIONES / VERBINDUNGEN

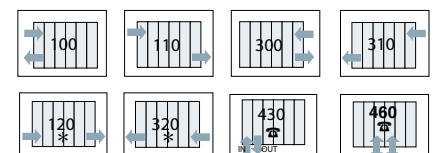

\*Inserendo il diaframma fornito a kit / By mounting the diaphragm  
☎ A richiesta / On demand



**Ragaini Radiatori S.p.A.**

Zona Industriale Brodolini, 46C  
60025 Loreto - (An) Italia

tel. +39 071 7500740 / +39 071 7500889  
fax +39 071 978814

[www.ragainiradiatori.com](http://www.ragainiradiatori.com)  
[www.madeadhoc.com](http://www.madeadhoc.com)

