



KITS



PUMPS



METERS



METERED NOZZLES



NOZZLES



WASTE OIL EQUIPMENTS

# CAMBIAOLIO

## FEATURES

- IDEAL FOR SMALL WORKSHOPS
- COMPRESSED AIR NOT REQUIRED
- 6 SUCTION PROBES INCLUDED
- VERSATILE
- VACUUM INDICATOR
- 5 METERS OF CABLE
- GRADUATED COLLECTION TANK
- EASY TO EMPTY

The CAMBIAOLIO is the traditional offer that PIUSI provides for a perfect oil change without the need of compressed air. This small device comes on a trolley that makes it transportable everywhere.

### PERFORMANCE

UP TO

**10L**

TANK CAPACITY

**AC/DC**

VOLTAGE

POWER

BELOW

**70DB**

NOISE LEVEL\*\*



CAMBIAOLIO

### PACKAGING

CODE	WEIGHT		PACKAGING			
	KG	LBS	MM	INCH	PCS/PALLET	PCS/BOX
FO05000B	19,5	43	600X290X300	23,6X11,4X11,8		1
OO050006A	19,5	43	600X290X300	23,6X11,4X11,8		1



FILTRATION



FLUID MONITORING



TANK MONITORING



HOSE REELS



ACCESSORIES



MERCHANDISE



AIR



ANTIFREEZE



AdBlue®



BIODIESEL



DIESEL



FOOD



GASOLINE



GREASE



KEROSENE



OIL



WATER



WINDSCREEN

## DIMENSIONS

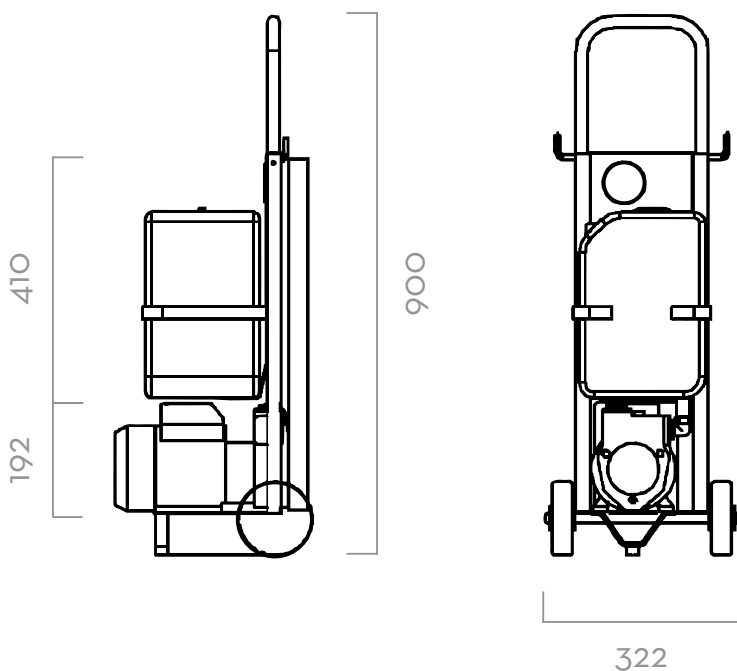

Dimensions expressed in millimeters

## IN THE BOX

- CAMBIAOLIO
- INSTRUCTION MANUAL

## DETAILS



## MATERIALS

- PUMP BODY: CAST IRON
- PUMP GEARS: BRONZE
- SHAFT: STEEL

## TECHNICAL DATA

CODE	DESCRIPTION	FLUIDS TYPE	FLOW RATE		VOLTAGE			TANK	
			L/MIN	GPM	AC V/HZ DC VOLT	POWER WATT	AMP. MAX.	LITER	GAL
FO050000B	CAMBIAOLIO M		2 - 10	0,5 - 2,5	230/50-60	350	2	10	3
OO050006A	CAMBIAOLIO 120V / 60 HZ		2 - 10	0,5 - 2,5	120/60	1200	12,7	10	3

# CAMBIAOLIO

ELECTRIC OIL DRAINERS

121